

**Product Instruction Data** (FORM NO. 4-21RD NDVV  
PIS)

Installation & Operating  
Instructions for Industrial  
Value V-Band, 4-21 Round  
Filter Housing (Model Nos.  
NDV2B, NDV2C, NDV2D,  
NDV2E, NDV2F)

1. **RECEIPT OF EQUIPMENT**

The housing and any optional equipment are packed individually for final assembly by the customer. Carefully unpack and check each item received against the packing invoice. DO NOT DISCARD ANY PACKING MATERIAL UNTIL THE HOUSING AND FILTERS ARE INSTALLED AND OPERATING PROPERLY.

2. **INSTALLATION**

**CAUTION:** PROPER SAFETY EQUIPMENT SHOULD BE WORN AT ALL TIMES INCLUDING GOGGLES, PROTECTIVE CLOTHING, STEEL TOED FOOTWEAR, PROTECTIVE GLOVES AND APPLICABLE BREATHING RESPIRATOR OR DEVICE.

Housings are supplied without cartridges installed. Refer to cartridge manufacturer installation instructions for cartridge installation or replacement.

**INSTRUCTIONS FOR MOUNTING:**

Refer to filter housing assembly drawing listed on specification page for parts labeling and orientation instructions.

2.1 Bolt housing legs to a permanent base to provide stability during pipework installation and filter cartridge replacement. Install housing to pipework allowing clearance for installation and removal of cartridges.

By-pass lines (if installed) should be closed unless fluid is needed during the filter replacement.

2.2 **IMPORTANT:** Install the housing to the pipework making certain that the fluid flow agrees with the flow direction indicated on the housing Inlet and Outlet.

3. **INSTALLING or REPLACING CARTRIDGES**

**CAUTION:** Do not at any time loosen or remove V-band closure mechanism before venting. Failure to open vent can result in pressurized fluid trapped in the vessel.

**Fluid under pressure may escape when closure mechanism is loosened or removed causing personal injury or damage to equipment.**

For identification and a list of replaceable housing spare parts, refer to Recommended Spare Parts Price List, 4-21 Round Offset (NDV2B, NDV2C, NDV2D, NDV2E or NDV2F) Industrial Value non-Code Housing. When cartridge replacement becomes necessary and before the limiting differential pressure is reached, (refer to cartridge manufacturer's literature for maximum allowable cartridge differential pressure), proceed as follows:

- 3.1. Close valve located immediately downstream of filter assembly.
- 3.2. Close valve located immediately upstream of filter assembly.
- 3.3. Do not stand over the assembly while opening Vent Plug to depressurize filter assembly. Open the bottom Drain Plug to release any remaining liquid. Be prepared to catch, contain and/or drain off this liquid.
- 3.4. After housing is fully drained, loosen Cover V-band clamp nut by turning T-Bolt handle or nut counterclockwise. Fully remove T-Bolt handle or nut and bolt from the retainer and place in a secure place. Remove cover, V-band clamp and gasket or O-ring and place in a secure place.
- 3.5. Remove polypropylene Fly Nuts from Hold Down Tie Rods by turning counterclockwise and place in a secure place. Lift Hold Down Plate off of Hold Down Tie Rods and place in a secure place. If housing possesses DOE cartridge connections, remove DOE Cup Spring Seal Assemblies (if provided) taking care not to drop the parts into the vessel and place in a secure place. Remove V-Posts or C-Posts by pulling with a gentle upwards and side to side motion and place in a secure place.
- 3.6. If cartridges possess 222 end adapters, remove filter cartridges by grasping lower end of cartridge and pulling away from the cartridge sockets on the Base Plate with a twisting motion. Discard filter cartridges in a suitable place.
- 3.7. Clean and wipe all parts of the filter housing clean with a clean cloth. Inspect all parts of the filter housing, particularly the housing gasket or O-Ring, for possible damage and/or excessive wear and corrosion. Replace any damaged or worn parts.
- 3.8. Replace V-Post or C-Post into the center opening on each cartridge cup by pushing gently in a downward motion. If the V-Post possesses a set of two tabs near the bottom end, push the post into the cup center until the tabs contact the DOE cup. If the C-Post does not possess the tabs, push the post into the center of the cup approximately two inches. If cartridges are DOE, position new cartridges over each V-Post or C-Post and ensure plain end or gasket on filter cartridge contacts the knife edge seal on the cup connection on the Base Plate. Replace DOE Spring Seal

- Assemblies into the center core on top of the cartridge ensuring the knife edge on Spring Seal contacts plain end or gasket end of the DOE cartridge. If cartridge connections are 222, wet cartridge O-rings with fluid to be filtered or a compatible lubricant. Position cartridges into cartridge socket by applying a simultaneous downward force and twisting motion until cartridge is fully seated per cartridge manufacturer installation instructions.
- 3.9. Place Hold Down Plate through Hold Down Tie Rods by aligning Rods with small holes in Hold Down Plate. If DOE cartridges are utilized, ensure the spring ends on the Spring Seal Assemblies lie flat against the Hold Down Plate. Secure Hold Down Plate by tightening polypropylene Fly Nuts to Hold Down Tie Rods in a clockwise direction. Tighten Fly Nuts equally to ensure the Hold Down Plate is level after all Fly Nuts are fully tightened. Tighten Fly Nuts approximately one inch downward or until approximately half of the spring free length on the DOE Spring Seal Assembly is removed.
  - 3.10. Replace gasket or O-ring onto Shell flange lip and replace Cover. Ensure the Cover is level and the outer edge of the head is aligned with the outer edge of the flange on the top of the shell. Place the V-band clamp around the shell flange and the Cover lip ensuring shell flange and the Cover lip are inside the retainer profile on the V-band clamp. Replace the clamp T-Bolt and tighten the T-Bolt handle or nut in a clockwise direction until a gap of approximately one-half inch ( $\frac{1}{2}$ " ) remains between the ends of the clamp.
  - 3.11. Replace bottom Drain Plug and tighten securely. Leave Vent Plug removed.
  - 3.12. Open valve located immediately upstream of filter assembly.
  - 3.13. When liquid is expelled from the Vent Plug, ensuring all air has been removed from the housing, securely tighten Vent Plug.
  - 3.14. Open valve(s) located immediately downstream of filter assembly.
  - 3.15. Operate the system for five minutes. Check for leaks at all threaded and flanged connections and at gasket or O-ring between Cover and Shell. Tighten connections as required.
  - 3.16. Do not exceed maximum pressure rating without contacting the factory for special instructions and approval. [150 psi (10.3 bar) @ 100°F (37°C)]

**Call the factory or contact your local distributor for spare parts and for genuine replacement elements.**

# Industrial Value Design **Offset, 21 Round**

Element Length	(A) Overall Height	(B) Vessel Height
30 - inch:	49.5" (125.7 cm)	46.0" (116.8 cm)
40 - inch:	59.5" (151.1 cm)	56.0" (142.2 cm)

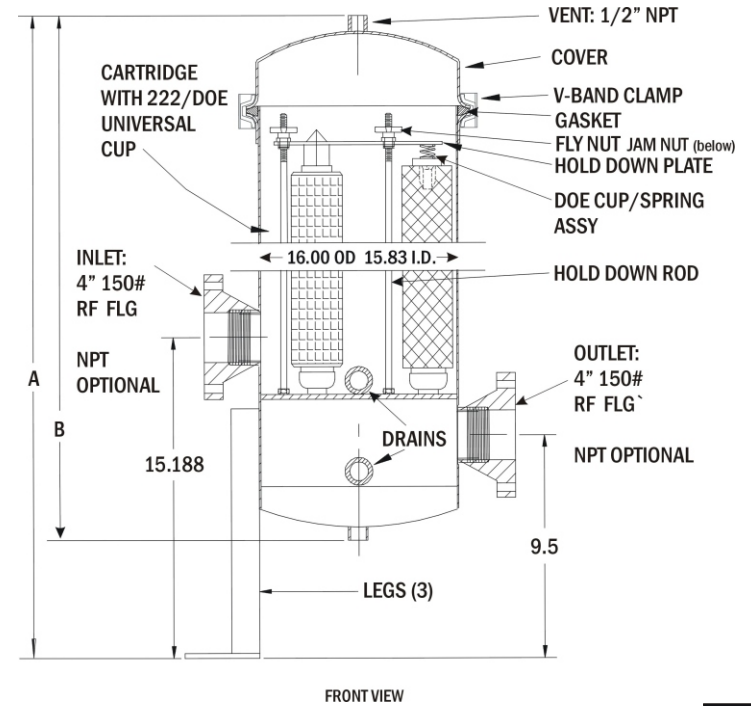
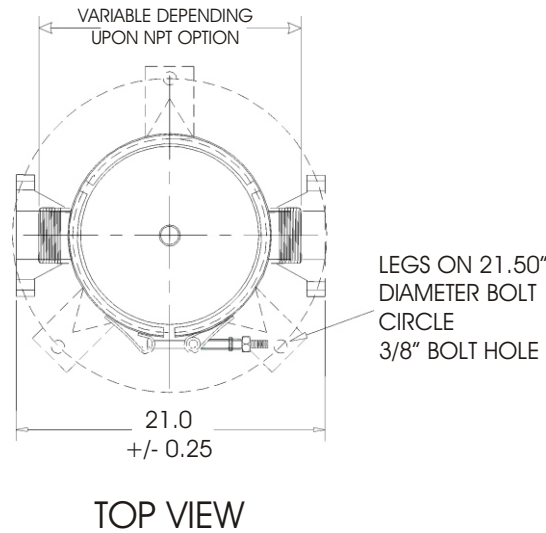
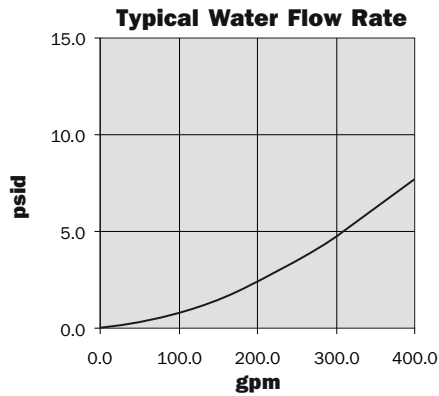

## Building a Model Number

Ordering is easy when you follow the Model Number Builder below. Reading from left to right, select which specifications you require and fill in the box with the code for that option. The end result will be a 15 digit model number.

**NDV** **2** **F**

This portion of the model is already completed for you.

**NDV** = Industrial Value Design  
**2** = Offset  
**F** = 21 Round

Material	Element Length	Cartridge Connection	Inlet/Outlet Connection	Drain Connection	Vent Connection	ID/OD Finish	Closure Type	ASME Code	Gasket Material
A 304L	3 30"	1 DOE	A 1½" NPTM	A ½" NPTF	A ¼" NPTF	1 SM/150	V V-Band	1 Non-Code	E EPDM
B 316L	4 40"	2 222	B 2" NPTM	B ¾" NPTF	B ½" TC	2 SM/150/EP			S Silicon
			C 3" NPTM	C 1" NPTF	C ¾" TC				V Viton
			D 2" RF Flange	D ½" TC	D 1" TC				T PTFE, Teflon
			E 3" RF Flange	E ¾" TC	E No Vent				B Buna
			F 4" RF Flange	F 1" TC					
			G 6" RF Flange	L 3" TC					
			H 1" TC	M 4" TC					
			I 1½" TC	N 1½" Grooved					
			J 2" TC	O 2" Grooved					
			K 2½" TC	P 3" Grooved					
				Q 4" Grooved					

**CLEAR LAKE INDUSTRIES**  
 "CLEARLY THE BEST"

920 Gemini St., Houston, TX 77058-2704  
 Tel: (281) 486-5085

www.clearlakeindustries.com  
 Fax: (281) 486-2609

**NDV Series**